



DANISH 01 ELECTRIC

USER MANUAL



Table of Contents

| | | |
|--------------|--|----|
| 1 | Safety in Roaster Operation | 5 |
| 1.1 | Important Symbols | 5 |
| 1.2 | Information Plate | 6 |
| 1.3 | Unit Identification QR Plate | 6 |
| 1.4 | Coffee Roaster Safety | 7 |
| 1.4.1 | General Information on Roaster Safety | 7 |
| 1.4.2 | Operator | 8 |
| 1.4.3 | Specialist | 8 |
| 1.4.4 | Supervisor | 8 |
| 1.4.5 | Understanding and Providing Ongoing Training | 9 |
| 1.5 | Potential Hazards | 10 |
| 1.5.1 | Electrical | 10 |
| 1.5.2 | Environmental Pollution | 11 |
| 1.5.3 | Fire | 12 |
| 1.5.4 | Over Temperature | 12 |
| 1.5.5 | Hot Surface | 12 |
| 1.5.6 | Safety Equipment | 13 |
| 1.5.7 | Emergency Push Button | 13 |
| 1.5.8 | Water and Fire Supply Prevention | 13 |
| 1.6 | Hazard Countermeasures | 14 |
| 2 | Introduction of Coffee Roaster Components | 16 |
| 2.1 | Anatomy of The Hartanzah Danish 01 Electric Roaster | 16 |
| 2.2 | Functions of Each Part of The Roaster | 17 |
| 2.2.1 | Hopper Inlet | 17 |
| 2.2.2 | Slider Valve | 17 |
| 2.2.3 | Coffee Door | 18 |
| 2.2.4 | Sampling Spoon | 18 |
| 2.2.5 | Chaff Tray | 18 |
| 2.2.6 | Main Control Panel | 18 |

| | | |
|----------|---|----|
| 2.2.7 | Emergency Stop Button | 19 |
| 2.2.8 | Cooling Tray | 19 |
| 2.2.9 | Agtron Sensor | 19 |
| 2.2.10 | Coffee Sight Glass | 19 |
| 2.2.11 | Main Power Socket | 20 |
| 2.2.12 | Exhaust Pipe | 20 |
| 2.2.13 | Danish 01 Electric Dimension | 21 |
| 3 | Coffee Roaster Operation | 22 |
| 3.1 | Emergency Stop Button | 22 |
| 3.2 | Safety Temperature Limit | 23 |
| 3.3 | Electrical Connection | 24 |
| 3.4 | Introduction of Main Panel | 25 |
| 3.5 | Turn on The Coffee Roaster | 26 |
| 3.5.1 | Initial Check of Coffee Roaster Function | 26 |
| 3.5.2 | Power on | 26 |
| 3.5.3 | Turn on The Drum | 26 |
| 3.5.4 | Turn on The Heater | 26 |
| 3.5.5 | Turn on The Air Flow | 27 |
| 3.5.6 | Clean The Chaff Tray | 27 |
| 3.5.7 | Auto Warming Up Function | 28 |
| 3.6 | Introduction of The HMI Menu | 29 |
| 3.6.1 | HMI Menu | 30 |
| 3.6.2 | Error System | 31 |
| 3.7 | Automatic Roast | 32 |
| 3.8 | Agtron Meter | 39 |
| 3.9 | Turning off The Roaster | 40 |
| 4 | Roaster Maintenance | 40 |
| 4.1 | Lubrication | 41 |
| 4.2 | Drum Front Bearing | 41 |
| 4.2.1 | How to Lubricate the Drum Front Bearing | 42 |
| 4.3 | Bearing Block | 43 |
| 4.3.1 | How to Lubricate the Bearing Block | 43 |

| | | |
|-------|---|----|
| 4.3.2 | Bearing Block Location | 44 |
| 4.4 | Cleaning the Machine | 45 |
| 5 | Transport, Packing, and Storage | 45 |
| 6 | Machine Installation and Placement | 46 |

1 Safety in Roaster Operation

There are important things that operators need to understand thoroughly before doing the coffee roasting process, from understanding symbols to how to maintain the roaster.

1.1 Important Symbols

Before starting roasting, the operator needs to pay attention to the symbols listed in this book or affixed to the roaster machine, so that the operator knows the potential hazards and acts carefully to avoid accidents, damage, and injury during the roasting process.



DANGER!

... indicates a hazardous situation which, if not avoided, will result in death or serious injury.



WARNING!

... indicates a hazardous situation which, if not avoided, could result in death or serious injury.



CAUTION!

... indicates a hazardous situation which, if not avoided, may result in minor or moderate injury.



ATTENTION!

... indicates a property damage message.

Disclaimer

Before continuing to read this book, it is highly recommended to know that all statements and tips in this book have been given to applicable standards, regulations, technical analysis, and years of experience.

The scope of delivery may deviate from the descriptions and representations described in this book for special version machines or custom options.

HARTANZAH will not be responsible for anything caused by:

- Not paying attention to this documentation
- Use of machines that are not in accordance with the manual
- Placement of untrained personnel
- Unauthorized changes or conversions
- Technical modification without written permission from HARTANZAH

“Safety isn’t expensive, it’s priceless.”

1.2 Information Plate

There are several information plates in the HARTANZAH roaster to assist the operator in understanding some information and prompts.

1.3 Unit Identification QR Plate

There are two QR plates attached to the HARTANZAH roaster, one plate is located on the main body of the roaster and the other plate is located on the body of the cyclone unit. This QR plate serves as proof of the authenticity of the machine, when scanned, it will appear in the web browser with detailed historical information about each machine.



Unit identification QR code

1.4 Coffee Roaster Safety

1.4.1 General Information on Roaster Safety

Please note that all safety aspects are important for the protection of all staff, machines, and facilities related to roaster operation, and full understanding is required for safe and trouble-free operation.

Non-compliance with the work instructions in this operating book may cause a significant safety hazard. Apart from the safety instructions in this manual book, applicable safety and accident prevention regulations should be considered.



Operators are required to understand all safety regulations and understand the risks that can occur while operating the system. Everyone working on the system must be aware of the risks and follow instructions to prevent those risks to avoid accidents or damage.

1.4.2 Operator

An operator is a person who has been instructed and has been given training by those who are related to the tasks assigned to them and has been aware of the potential dangers that arise from incompetent behavior.

1.4.3 Specialist

A specialist is a person who can carry out the tasks assigned to them and recognizes potential hazards for themselves with their professional skills, knowledge, and experience.

1.4.4 Supervisor

Authorized to restart the installation after a failure (e.g. EMERGENCY-Emergency button is pressed) while maintaining safety regulations.

Besides must understand and carrying out the health and safety instructions in this book, the operator must also comply with the applicable health and safety instructions at their respective work sites. This applies specifically to operators.

Operators must always be aware of applicable occupational health and safety regulations to determine the potential hazards that may arise from certain working conditions by conducting a hazard analysis.

This analysis must be practiced through operating instructions, approved, and monitored by the supervisor.

The operator must verify the entire period of the use of the installation, whether the operating instructions made by them are by the conditions of the current rules or regulations, and

must make adjustments immediately if necessary.

directly with operations have read and understood the instructions.

Supervisors must ensure that all operators who work and/or deal

1.4.5 Understanding and Providing Ongoing Training

Supervisors are committed to informing operator personnel of existing statutory provisions, respective accident prevention regulations, and safety devices, to provide them with guidance. The different skills of staff members must be considered. The operator must fully understand the instructions described in this manual book and follow the directions of the supervisor.

A photograph showing a person in a blue shirt operating a coffee roaster machine. The person's hands are visible, adjusting a dial on the machine. The machine is black with a large, curved, perforated metal front panel. The background is blurred, showing a workshop or factory setting.

“Coffee roaster operators must be constantly reminded and actively briefed under the full supervision of an experienced person”

1.5 Potential Hazards

This section describes the potential hazards involved in operating the roaster. Follow the safety instructions, notices, and warnings stated in this manual to reduce, understand, and respond to health hazards and hazardous situations.

1.5.1 Electrical



DANGER!

Risk of death from electric current!



If electrical parts are touched, there is an immediate risk of death. Damage to the insulator of each component can cause the risk of death.

Therefore:

- If the insulation is damaged, turn off the supply voltage and have it repaired.
- Electrical system should be carried out only by experienced and responsible personnel.
- During all work on the electrical system, turn off the system and check that there is no voltage.
- Before performing assembly or disassembly, turn off the supply voltage and check before turning on the unit.
- Do not connect or cause fuses to malfunction.
- Keep the electrical parts dry. Moisture can cause a short circuit.

Pay attention to the operating rules of electrical devices that apply in each country!

1.5.2 Environmental Pollution



WARNING!

Environmental damage due to lubricant waste!
Lubricants contain substances that are toxic to the environment which can cause water pollution.

Lubricants must not penetrate the soil, water, or gutters. Therefore, every replaced lubricant must always be collected in a suitable place. Properly dispose of the lubricant after the lubricant replacement process is complete. In a coffee roaster, lubricant is found in the motor gearbox.



1.5.3 Fire



DANGER!

Injury due to fire hazard!

During the roasting process, an exothermic reaction and gases released from the interior of the roaster may occur which can be combined with the formation of sparks causing carbonization or fire. Therefore, empty the machine when the process is complete and cool the machine to approximately 40°C before turning it off. The Hartanzah Roaster has a "safe stop function" feature where the drum will continue to rotate if it is turned off manually if the temperature inside the drum is still above 40°C.

1.5.4 Over Temperature



DANGER!

There is a potential fire due to overheating when the burner is operating. Make sure the over-temperature function is working properly.

1.5.5 Hot Surface



WARNING!

The danger of burning due to hot surfaces!

Do not touch the surface of the roaster during the roasting process. Burns on the hands may be the consequence. Therefore, always maintain a safe distance marked with a barrier.

1.5.6 Safety Equipment



WARNING!

Danger by malfunctioning safety equipment!

Safety installation provides maximum safety during operation. Even if the work process becomes longer due to the safe installation, it should not be canceled. Security is guaranteed only with a complete security installation. Therefore, check before turning on the roaster, whether the safety equipment installation is fully functional and properly installed.

1.5.7 Emergency Push Button



WARNING!

Deadly danger by restarting the engine out of control!

Uncontrolled restarting can cause severe damage to people or death. Before restarting, ensure that the cause of the emergency shutdown has been addressed and all safety installations are installed and functioning. **Release the emergency stop button only when there is no danger.**

1.5.8 Water and Fire Supply Prevention



The water connection with the hose must be installed around the roaster and make sure there is always water during the roasting process. **Make sure the fire extinguisher (APAR) is always close to the roaster and make sure the operator can use it.**

1.6 Hazard Countermeasures

Recommended action in case of danger to life and limbs.

- Do not panic.
- Immediately turn off the machine.
- Perform first aid measures.
- Recover anyone from the danger zone.
- Notify the duty officer on site.
- Call a doctor and/or fire department.
- Clear access roads for rescue vehicles.

If there is a roaster fire, don't panic and leave the coffee beans

in the roaster, don't empty it.

Focus on the steps below:

- Press the EMERGENCY button.
- Turn off the power.
- Spray a fire extinguisher.
- Allow the engine to cool down.

If there is a fire in the Cooling Tray.

- Do not panic.
- Close the gas supply.
- Press the EMERGENCY button.
- Spray burnt coffee beans with water.

Hartanzah Roaster (Danish 03 above) has been equipped with a water suppression system that can automatically spray water into the drum and cyclone if there is an increase in temperature above the normal roasting temperature. You can change this temperature value but we recommend that the temperature value remains at the factory's initial setting.

**“When pressure builds up, don’t panic. Pray!
Prayer is a tremendous stress reliever. It can be your safety
valve.”
— Rick Warren**



2 Introduction of Coffee Roaster Components

2.1 Anatomy of The Hartanzah Danish 01 Electric Roaster

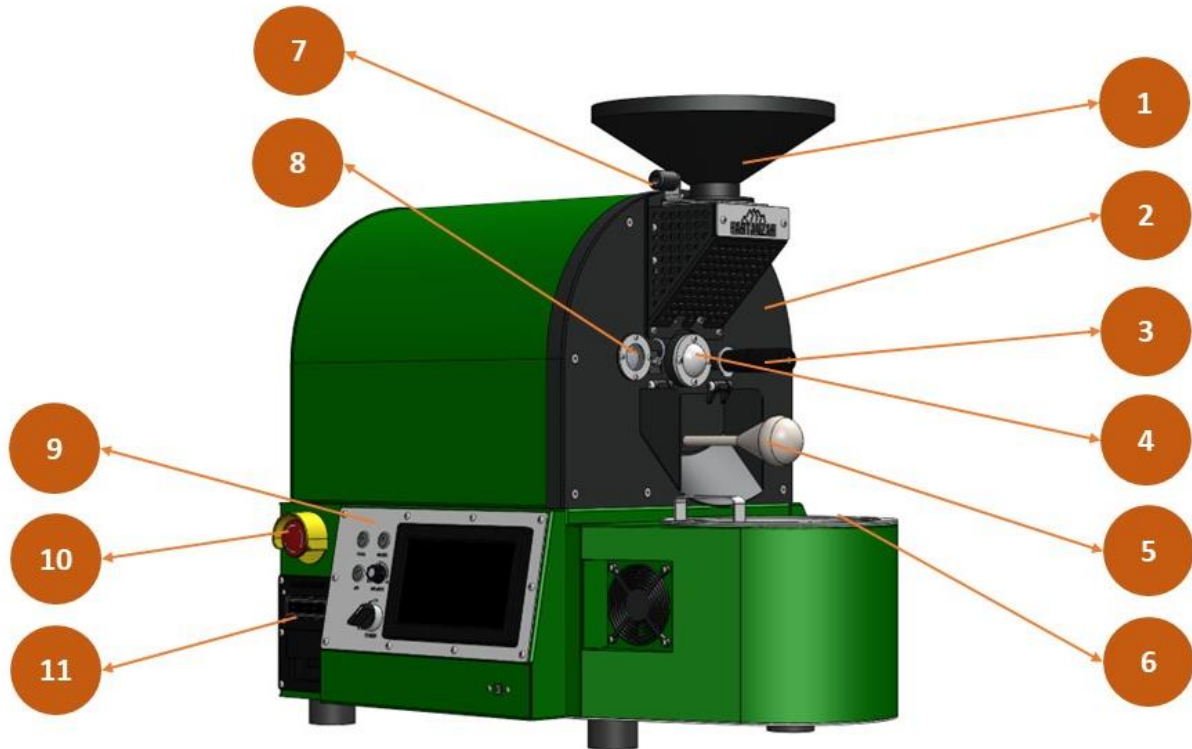

1. Inlet hopper
2. Face plate
3. Sampling spoon
4. Main bearing
5. Main door
6. Cooling tray

7. Slider valve
8. Sight glass
9. Main Control panel
10. Emergency stop button
11. Agtron color sensor



12. Chaff tray
13. Exhaust pipe



14. Burner chamber
15. Power outlet

2.2 Functions of Each Part of The Roaster

2.2.1 Hopper Inlet



The function of the chute inlet is as a container for raw coffee beans before entering the drum (roasting chamber).

2.2.2 Slider Valve



As an opening valve for raw coffee beans into the drum.

2.2.3 Coffee Door



As a closing door between the drum and the cooling tray. When opened, the coffee beans will come out of the drum into the cooling tray.

2.2.5 Chaff Tray

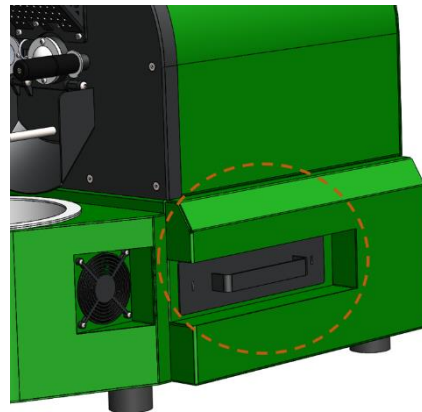

As a container for dirt or small objects that pass through the gap between the drum and the face flange.

2.2.4 Sampling Spoon

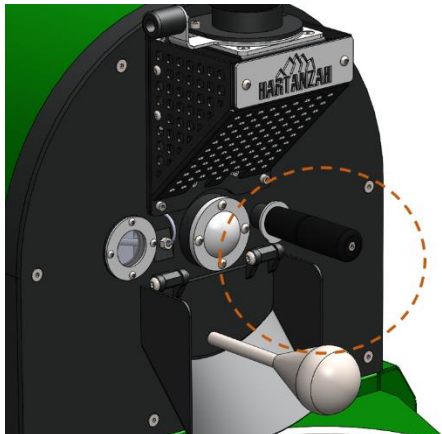

To take coffee beans from the drum.

2.2.6 Main Control Panel



As the control center of the roaster machine.

2.2.7 Emergency Stop Button



As a quick breaker in an emergency.

2.2.9 Agrtron Sensor

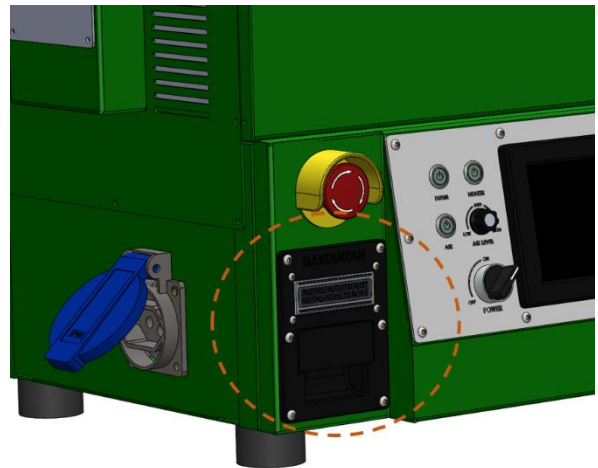

To read the results of roasting levels.

2.2.8 Cooling Tray

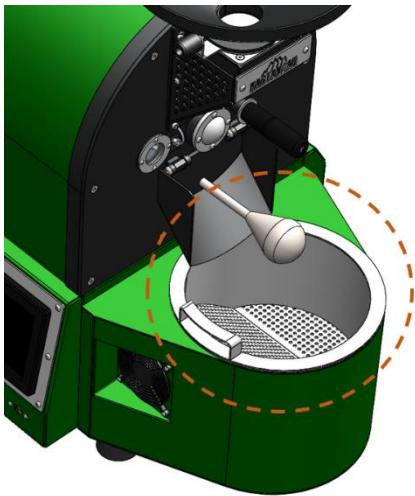

To cool the coffee beans after the roasting process.

2.2.10 Coffee Sight Glass



As the access to see inside the drum.

2.2.11 Main Power Socket



As the main electrical power outlet that is connected to the facility's electrical outlet.

2.2.12 Exhaust Pipe

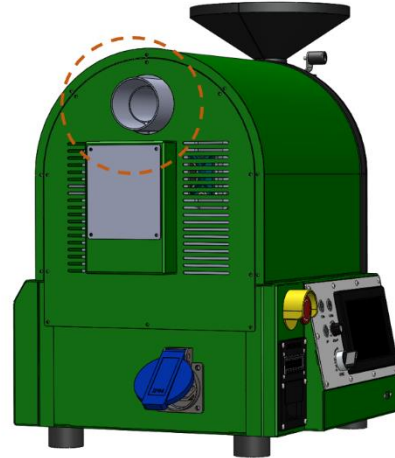

Stainless steel 3-inch pipe for the exhaust line of coffee roasting fumes.



2.2.13 Danish 01 Electric Dimension

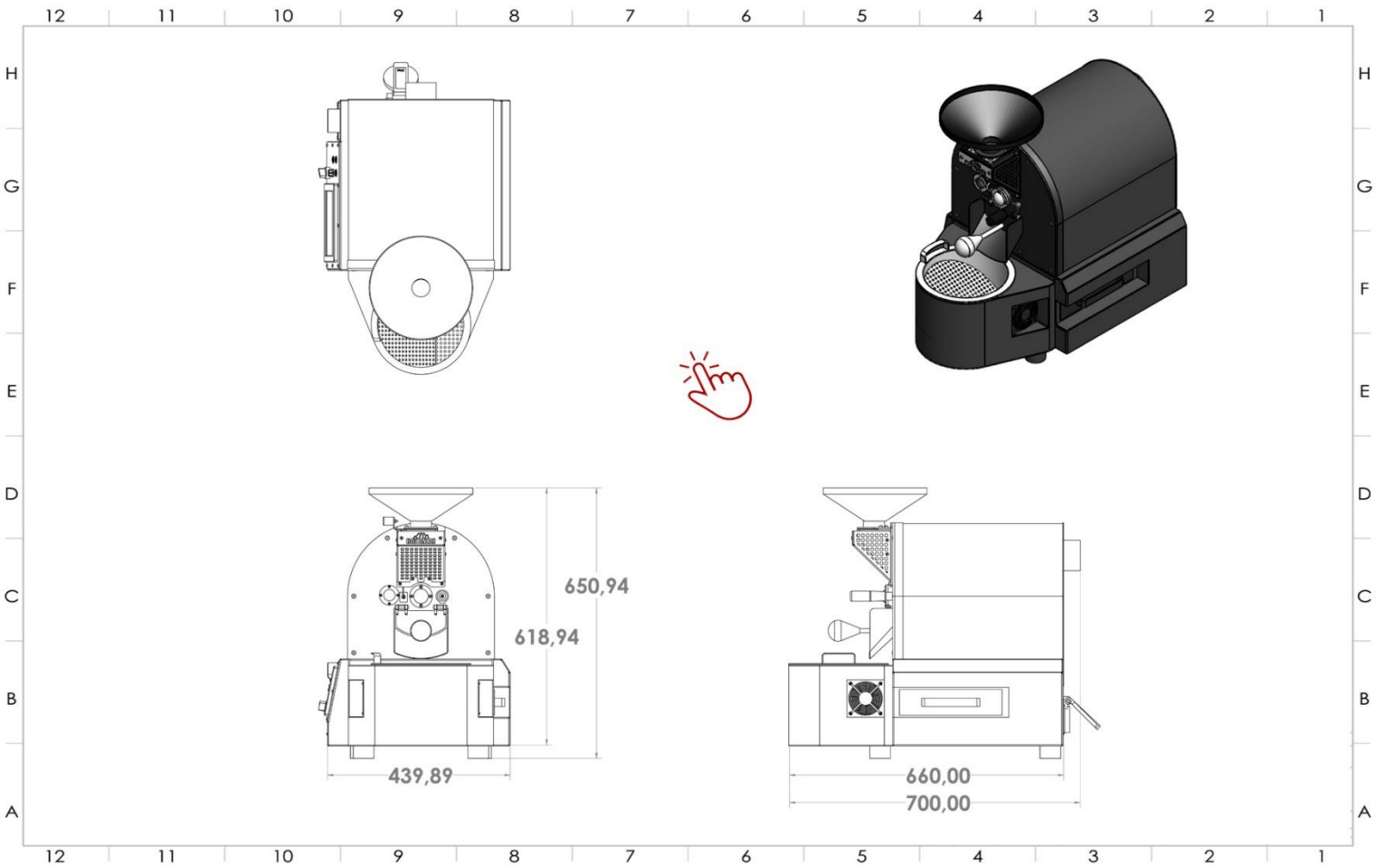

Images, sizes, and specifications are subject to change without prior notice. We continually update the design, features, and specifications to enhance machine performance.

3 Coffee Roaster Operation



It is important to thoroughly understand the proper ways before operating the HARTANZAH roaster and understand what to do in case of an emergency.

3.1 Emergency Stop Button



The emergency button is located on the side of the control panel. Activate this button by pressing the red button.

After pressing the emergency button, restarting must be carried out only by an authorized safety officer or supervisor who complies with safety regulations and has ensured that an emergency has not occurred.



Unlock the emergency button, it can be done by pressing the red button, while pressing the red button, turn to the right (CW) of the red button and release it.

3.2 Safety Temperature Limit

HARTANZAH roaster is equipped with a safety temperature limiter that turns off the burner automatically when the temperature inside the drum reaches 260 °C.

If this temperature limit occurs, the engine must be cooled under 240 °C (heater off) until the ignition of the new burner can be done again. This temperature limit setting can be done on the HMI menu.

The way to set the safety temperature limit is by clicking Menu (1) and then click Temp Limit (2), then entering the information at what temperature you want the system to turn off the heater automatically (3). The maximum limit is 260 °C. After that, click the “Set” button (4).

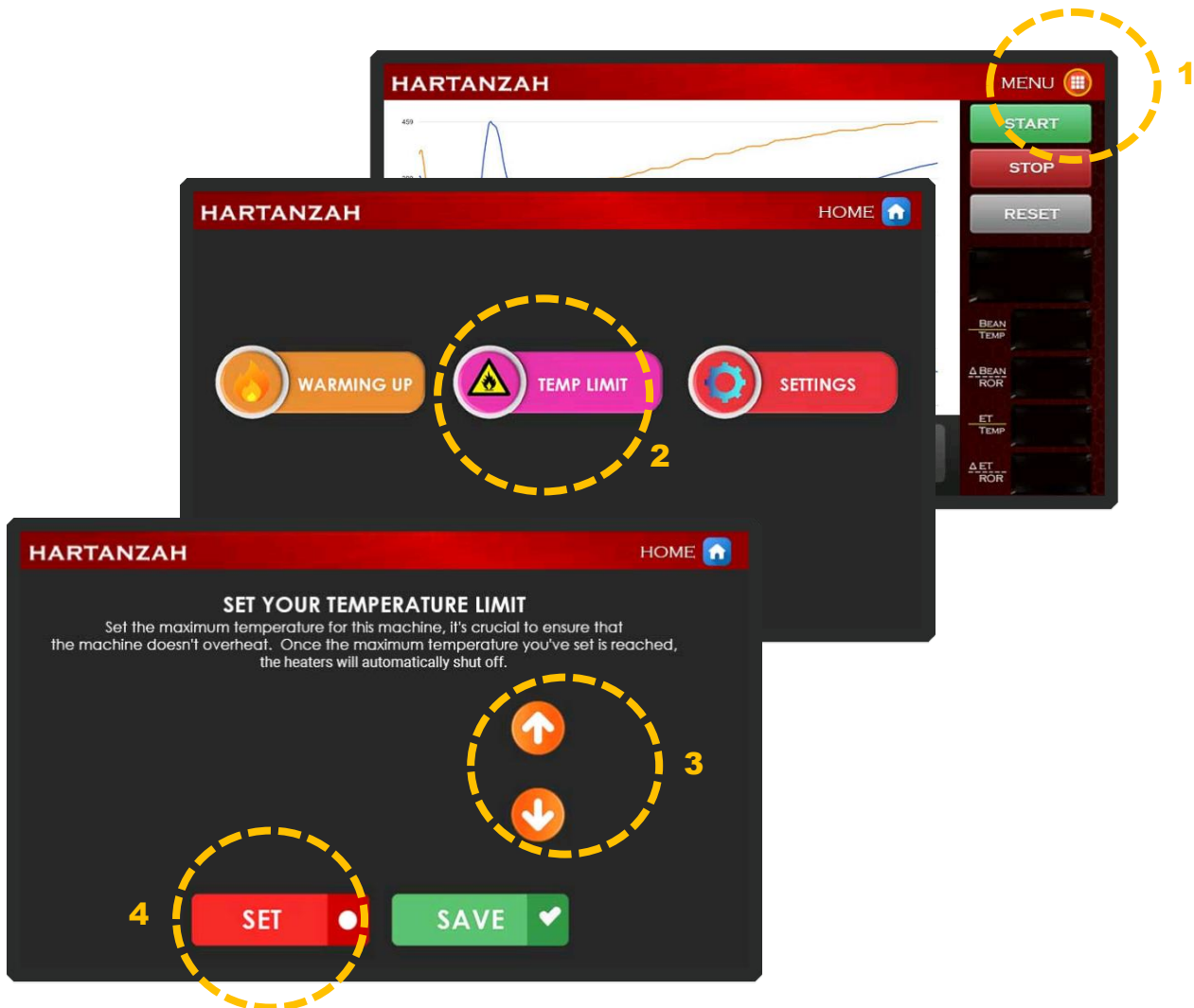

3.3 Electrical Connection

To provide electricity to the roaster, connect the main power cable (1) to the power outlet in the facility.



It is highly recommended for the installation of grounding in the facility's electrical installation and it is also highly recommended to use a UPS and stabilizer to support the supply of electricity remaining available when problems occur in the main power supply.

3.4 Introduction of Main Panel



- 1. Power on/off selector
- 2. HMI touchscreen monitor
- 3. Communication port
- 4. Heater on/off button
- 5. Drum on/off button
- 6. Airflow on/off button
- 7. Airflow volume

3.5 Turn on The Coffee Roaster

3.5.1 Initial Check of Coffee Roaster Function

Before starting the roasting process, the first time the machine is turned on, check all the machine functions first, with the following steps.

3.5.2 Power on

To start the roaster, turn the power selector knob to the right to turn on the engine and turn to the left to turn off the engine.



Make sure all power cords are plugged in and gas is available before starting the engine.



3.5.3 Turn on The Drum

Press the drum button and check through the sight glass that the drum is rotating.

Press again to stop the drum from spinning.



3.5.4 Turn on The Heater

Press the heater button and check through the monitor whether the temperature is rise. Press the button again to turn off the heater.

3.5.5 Turn on The Air Flow

Press the air button to turn on the airflow.

Turn the knob to the right to increase the airflow and to the left to decrease the airflow.



3.5.6 Clean The Chaff Tray

Check the cleanliness of the chaff tray, and make sure there is no remaining dirt from the previous roasting process. Chaff is very flammable, and undisciplined in cleaning chaff often result in fires.



Open the chaff tray (12) and dump the chaff. Make sure it cleans before start roasting.

3.5.7 Auto Warming Up Function

Danish 01 has a very helpful function for operators to easily warm up the roasting machine. With this feature, operators can effortlessly warm up the machine by inputting the desired target temperature, and once that temperature is reached, Danish 01 will provide an audible notification.

To use this automatic warming up feature, click the menu button (1) followed by clicking the warming up button (2), and the automatic warming up process will begin.

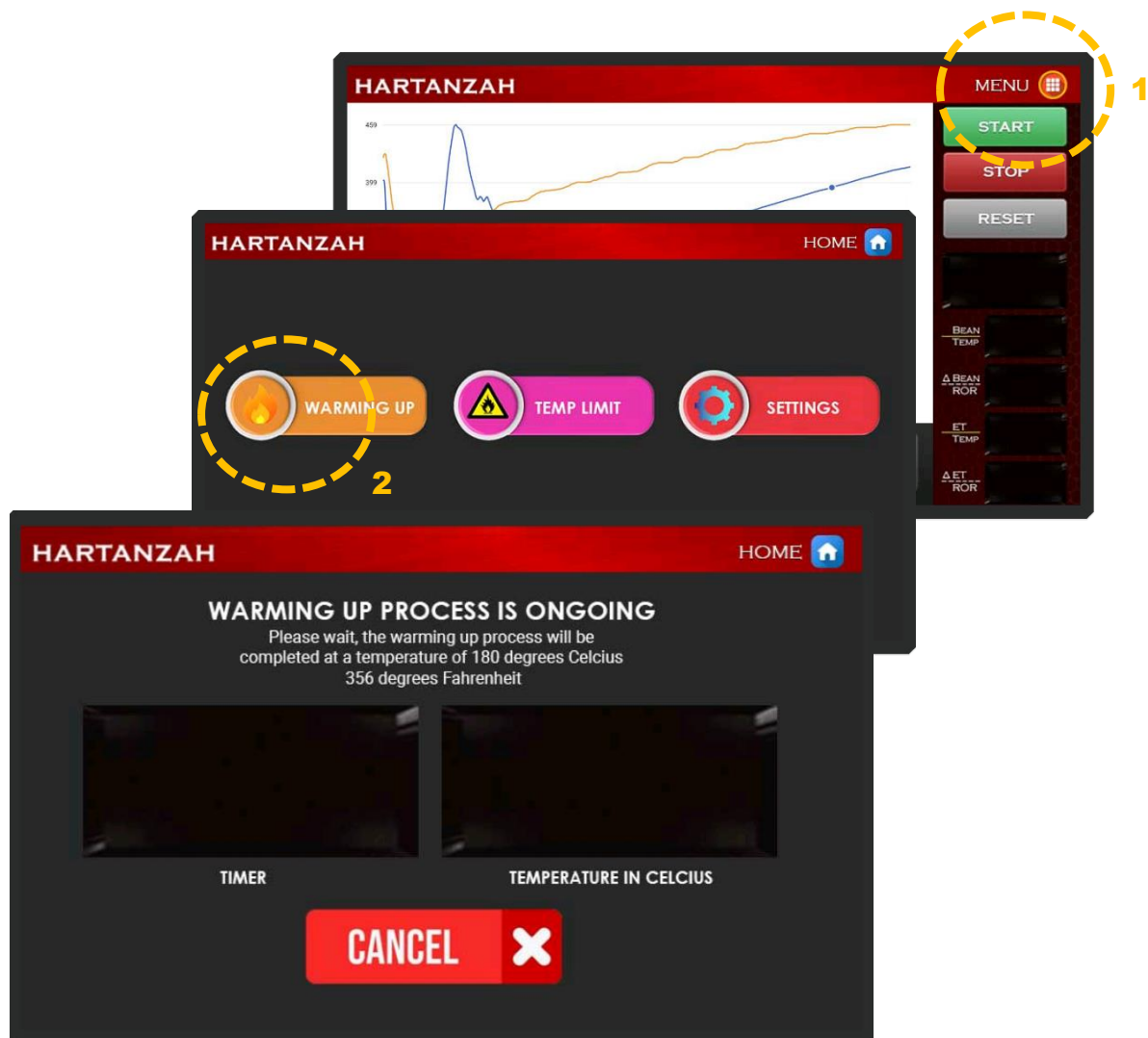

3.6 Introduction of The HMI Menu

The touch screen HMI (Human Machine Interface) is a standard component in all Hartanzah roasters, designed with a user interface that makes it easy for operators to operate the coffee roaster and explore the roasting process to produce the desired coffee taste.



3.6.1 HMI Menu



1. Roasting Curve: This section displays the curve of the Bean Temperature and Environment Temperature.
2. Heater Level: Displays the percentage of the heater.
3. Heater Button Up: This button is used to increase the heater.
4. Heater Button Down: This button is used to decrease the heater.
5. Color Sensor: This button is used to turn the Agrtron color sensor device on and off.
6. Menu: This button is used to open other menus, such as the warming up menu, settings menu, and safety shutdown menu.
7. Start Button: Used to display the roasting graph.
8. Stop Button: Used to stop the display of the roasting graph.
9. Reset Button: Used to reset the roasting graph.
10. Timer Display: Displays the roasting time. The timer will run when the start button is pressed and will stop when the stop button is pressed.
11. Bean Temperature: Displays the temperature of the coffee beans.

12. R.O.R. Bean: Displays the rate of rise for the coffee beans.
13. Environment Temperature: Displays the temperature inside the drum.
14. R.O.R. Environment: Displays the rate of rise for the environment temperature.

This safe shutdown feature is found on every Hartanzah roaster. If you turn off the drum when the drum temperature is still above 40°C, the system will continue to rotate the drum and will stop automatically after the temperature in the drum reaches 40 °C. This system is very important to prevent deformation of the drum structure and the drum time life. Generally, deformation and damage to the drum occur due to turning off the drum rotation when the drum temperature is above 40 °C.

3.6.2 Error System



Violent shocks, excessive electric currents, and incorrect transmissions can result in damage to the control system and touch screen.

Contact Hartanzah's technician if there is damage to the control system. Software repairs on the Hartanzah machine are carried out by reprogramming the system via the communication socket on the panel board (which can only be done by trained technicians).

3.7 Automatic Roast

The automatic roasting feature on the Hartanzah roasting machine allows you to automatically roast coffee following a pre-existing roasting profile. The way to use the automatic roasting feature is as follows.

Download and install the Hartanzah RoastWorks software by the following link:

<https://www.hartanzah.com/roastworks.html>

Connect the USB cable from the computer on which the Hartanzah RoastWorks software has been installed to the Hartanzah roasting machine. The USB connection port is located behind the HMI panel board. Continue by opening the Hartanzah RoastWorks software.

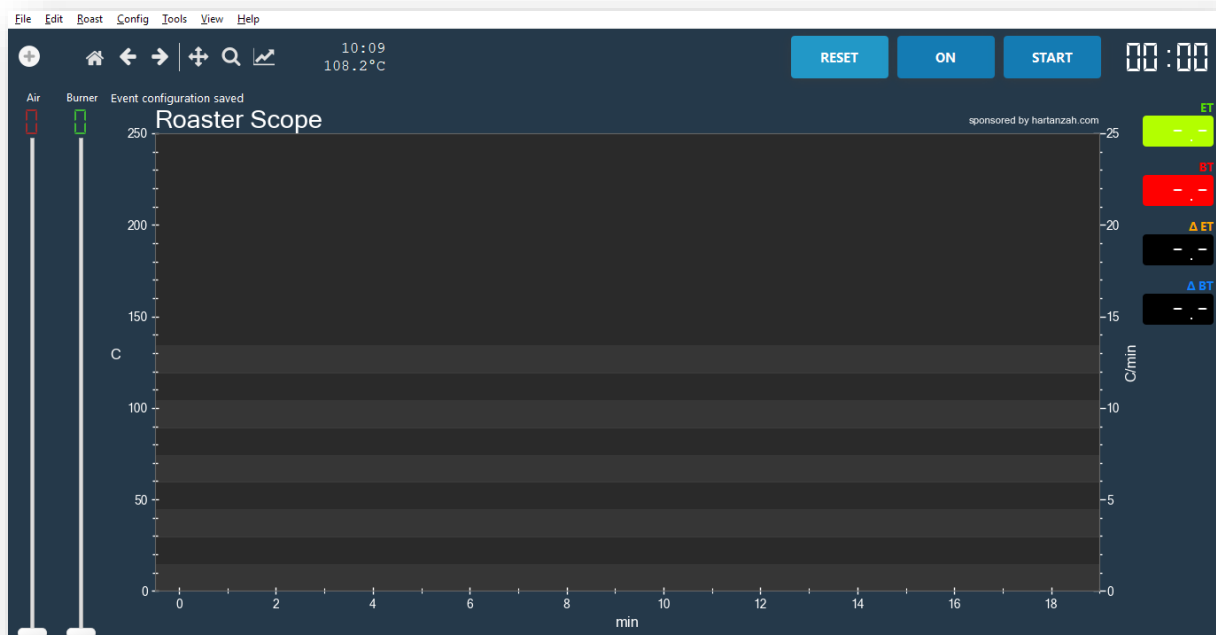

Continue by selecting the Config > Machine > Hartanzah Roaster menu to connect the Hartanzah RoastWorks software with the Hartanzah roaster machine.

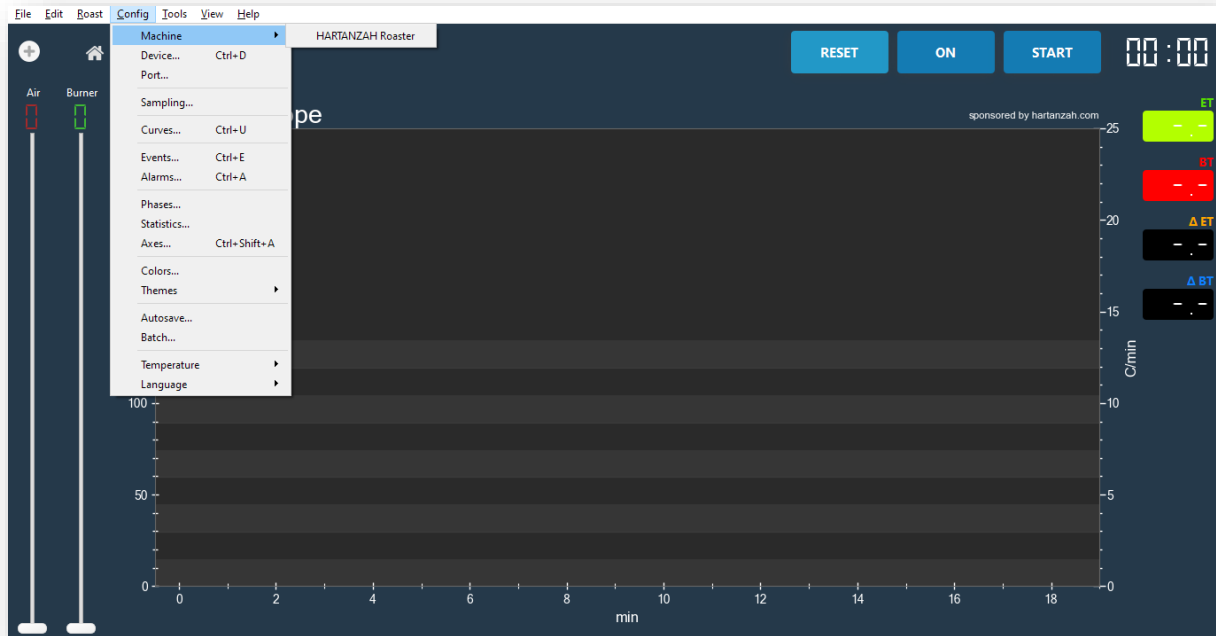

Adjust the communication port configuration in the computer device manager.

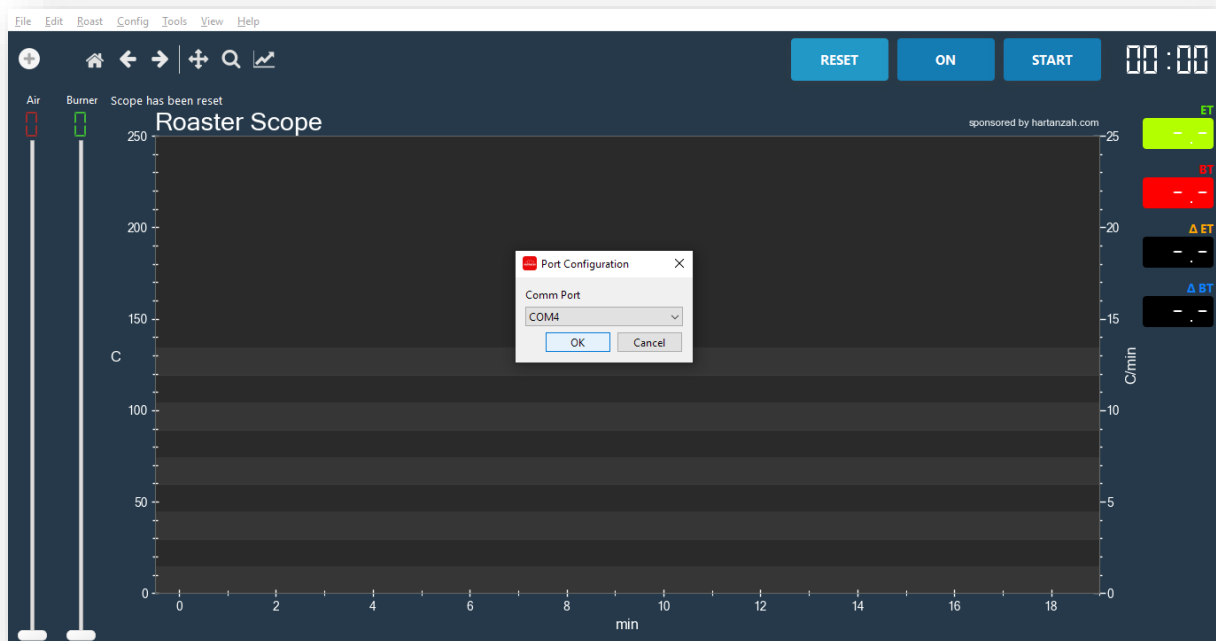

Adjust the Hartanzah roasting machine series that will be controlled.

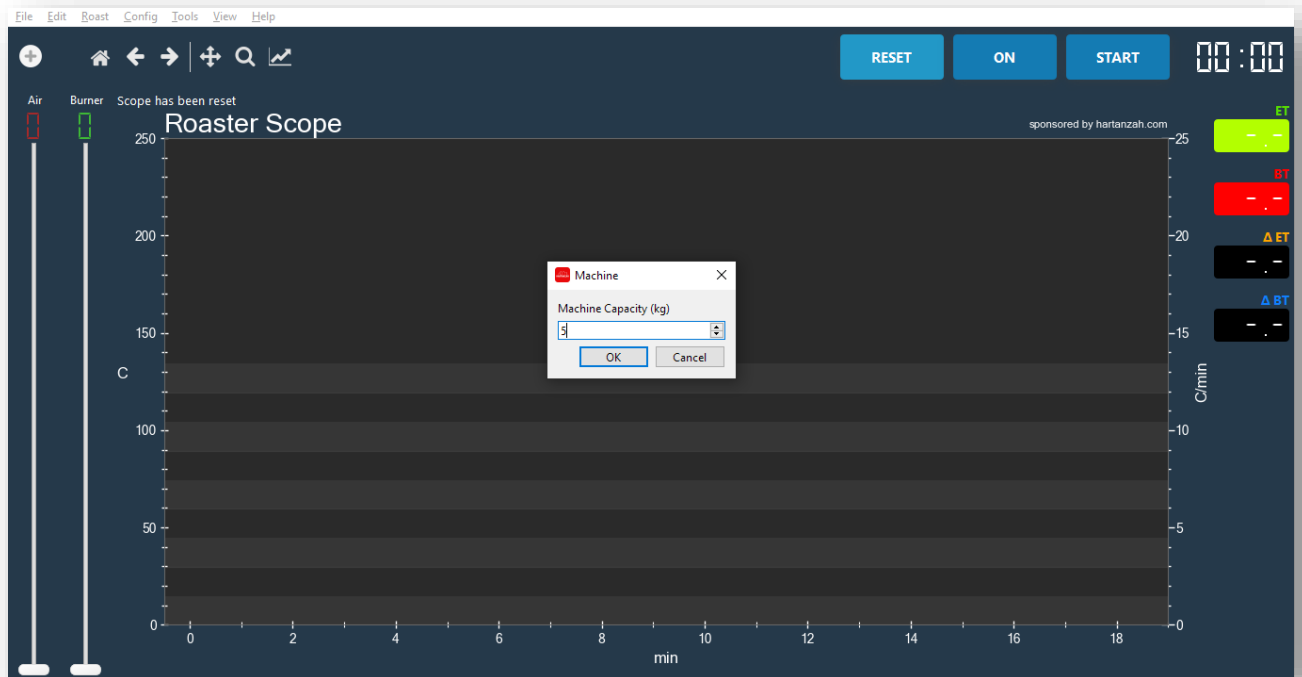

Adjust the heating type of the Hartanzah roasting machine to be controlled.

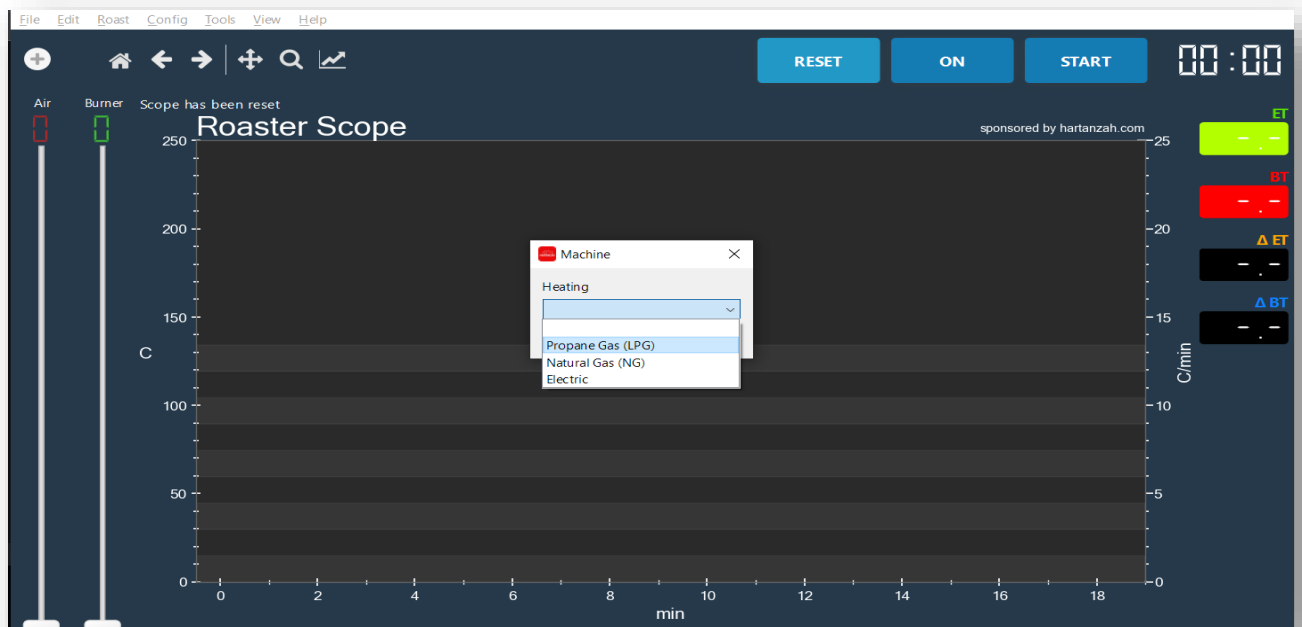

Continue by selecting the Config > Device menu.

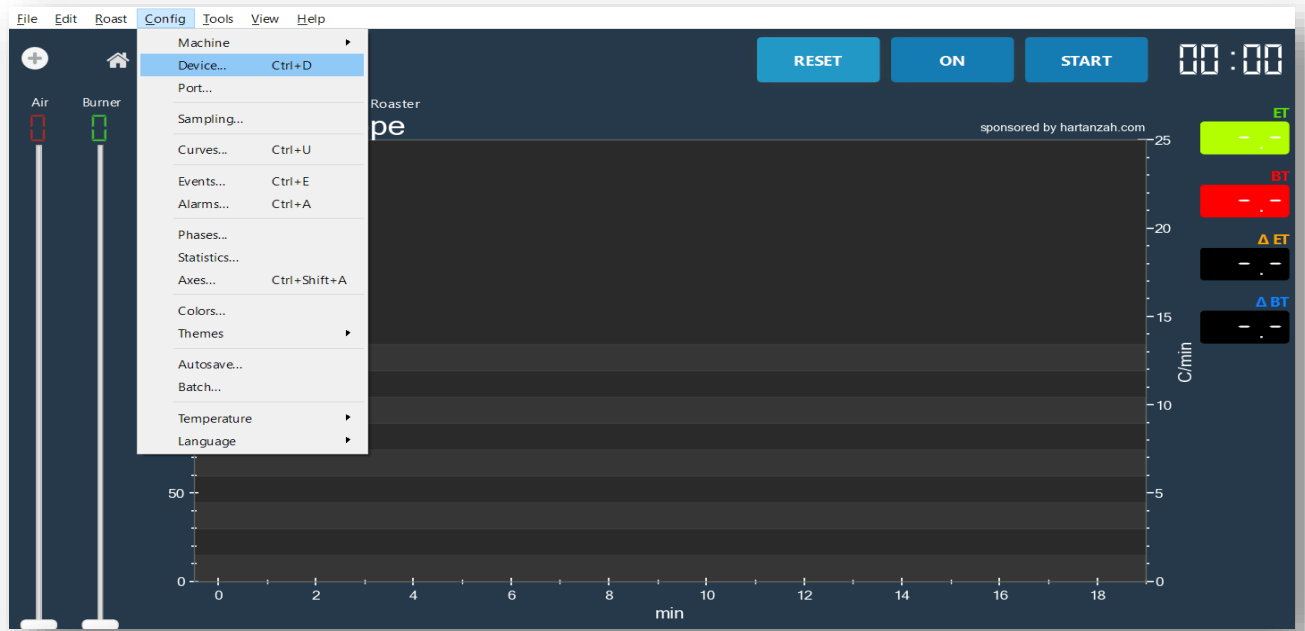

Select the machine configuration using MR1.

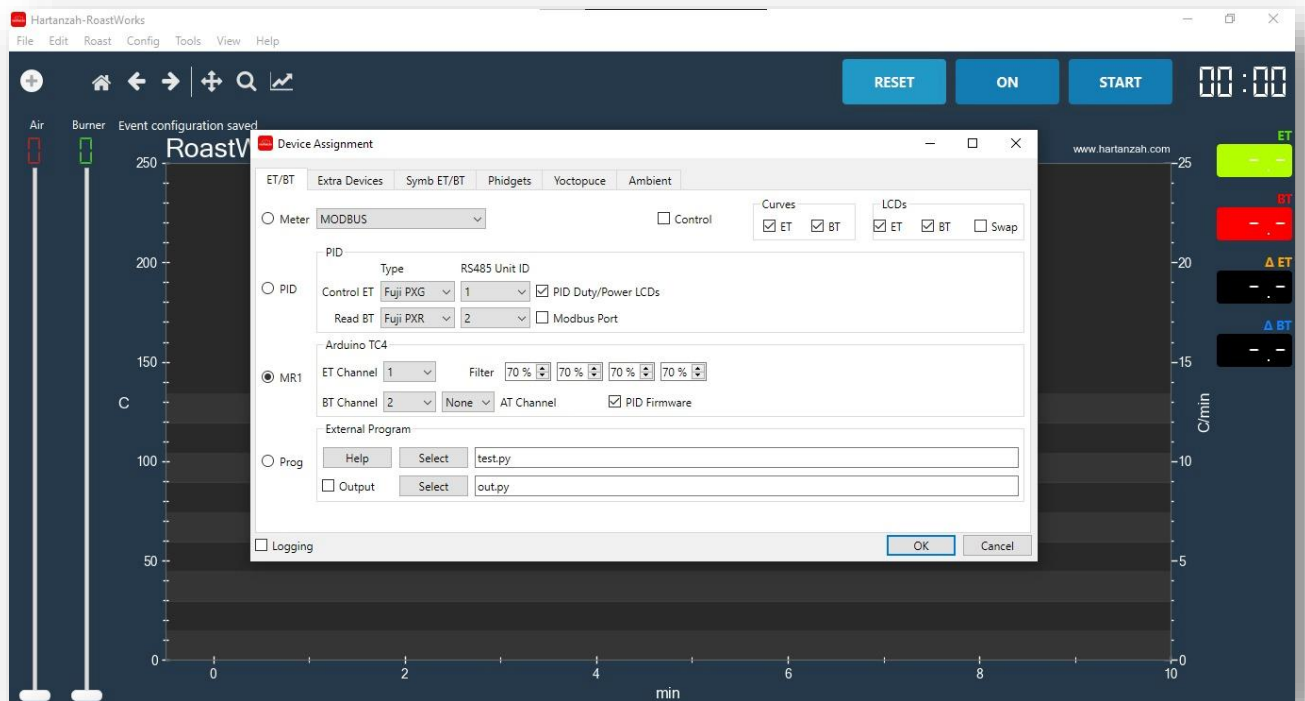

Adjust the Comm Port with the one in the computer device manager.

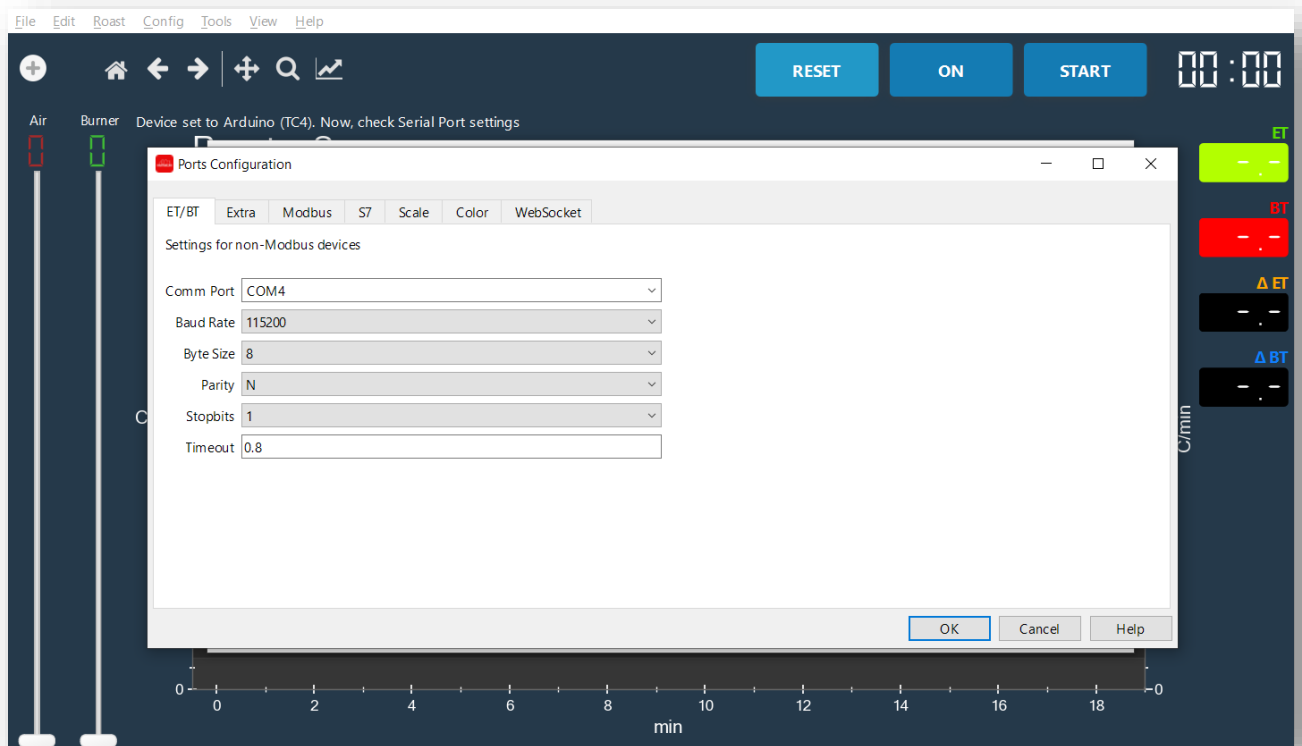

Select the background profile that you want to duplicate automatically.
Select the Roast > Background menu.

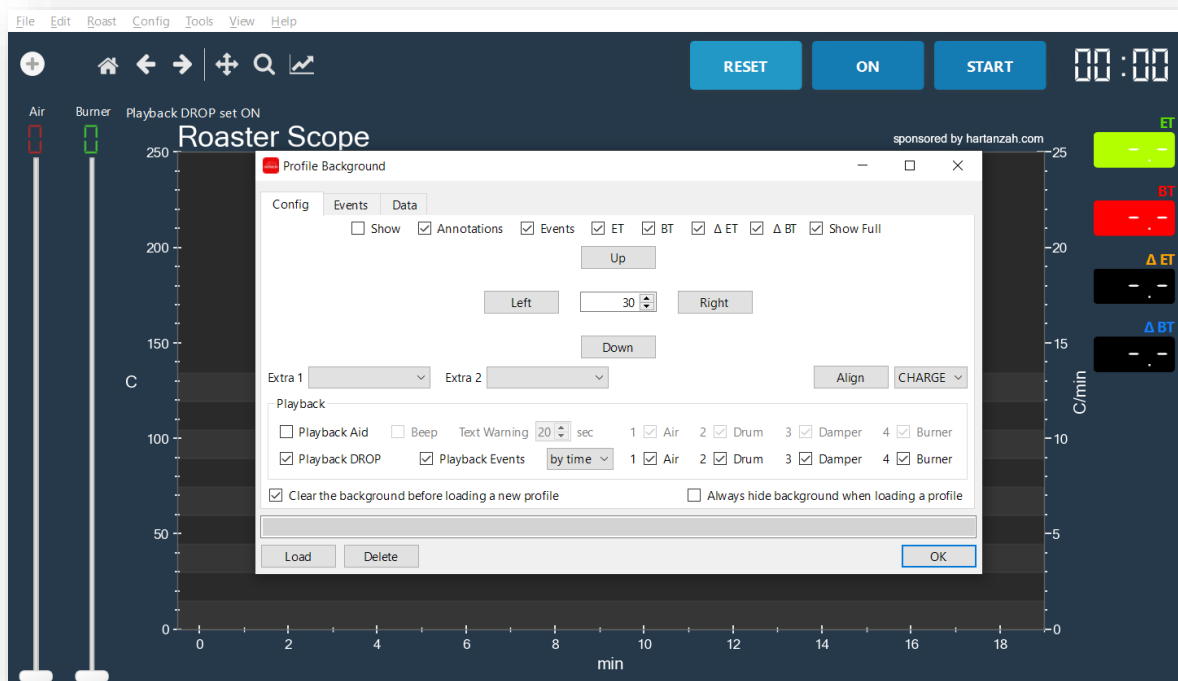

Adjust the settings exactly like the example below then select "Load" to call the roasting profile you want to duplicate.

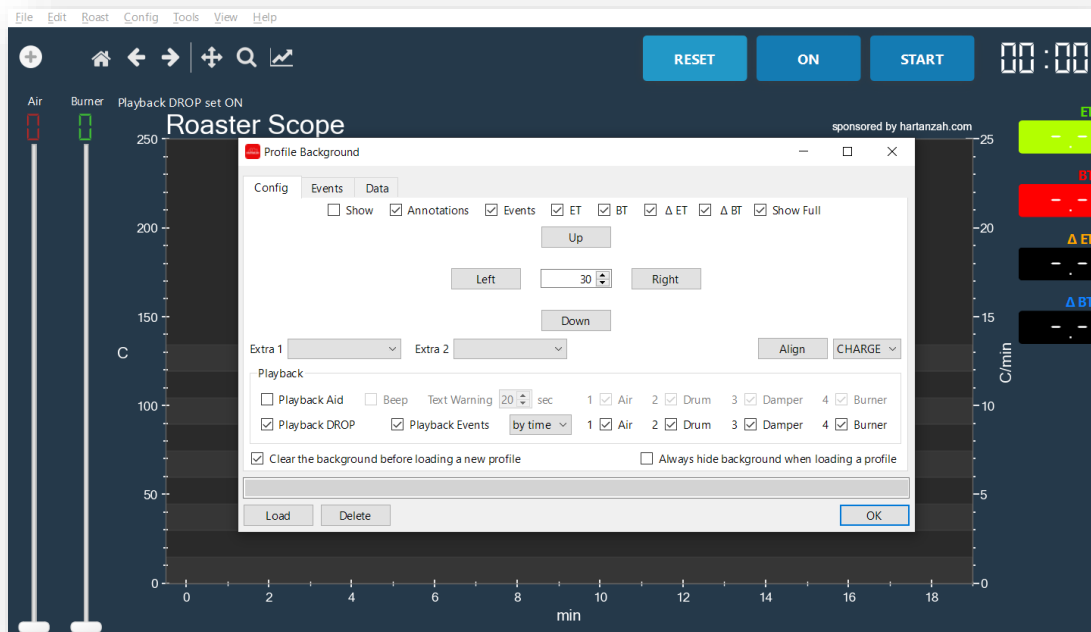

If it has been selected, the profile to be duplicated will appear on the Hartanzah RoastWorks software graphic. Continue by pressing the "ON" button.



Press the "START" button to make the Hartanzah machine roast automatically according to the previously opened profile.

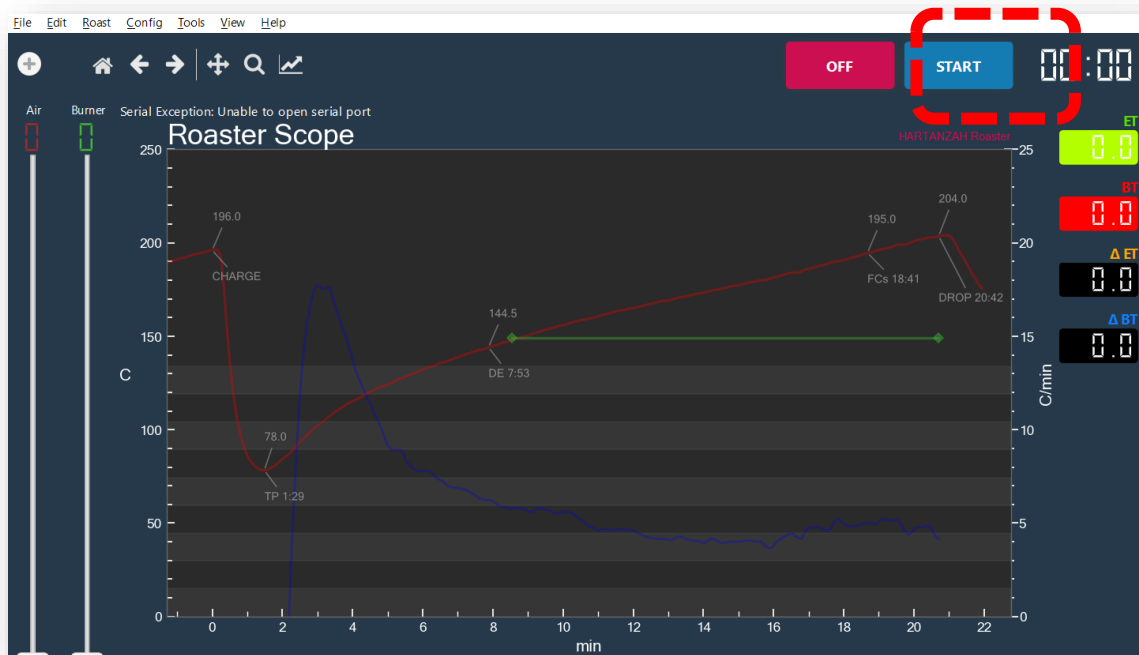

3.8 Agtron Meter

The Hartanzah roaster machine has an Agtron meter which is a tool to help the operator determine the roasting level that has been achieved, by measuring the color of the coffee beans that have been roasted. Color measurement using the Agtron meter is carried out by placing the roasted coffee beans into the Agtron meter container and immediately starting the measurement process.

On the Agtron meter LED screen, there are Agtron #85 to #25. This number shows the change in color of the coffee beans at each roast level. Large numbers indicate a lighter color of coffee beans.

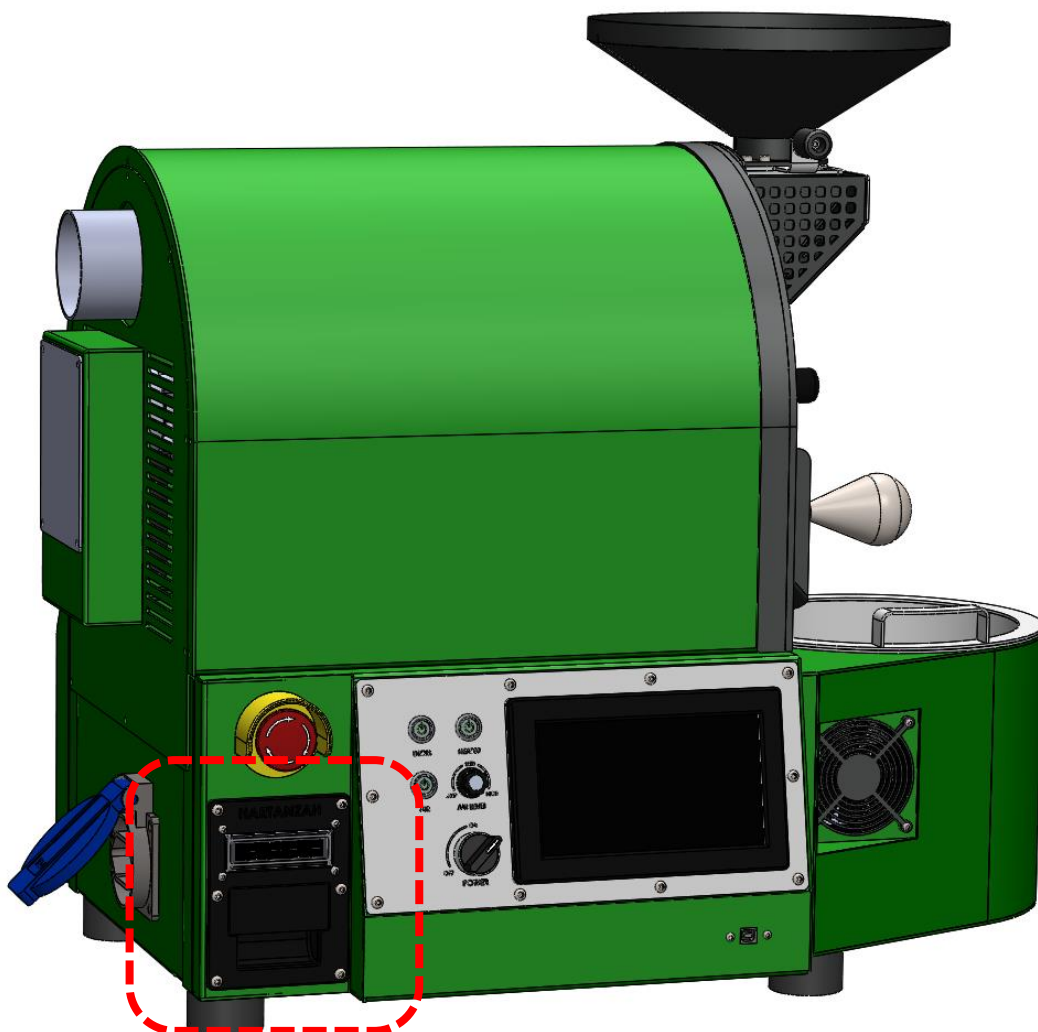

3.9 Turning off The Roaster

! Turning off the roaster machine in an inappropriate way can cause damage to the machine.

- Turn off the drum rotation when the temperature is below 40 degrees Celsius. Turning off the drum rotation when the temperature is high can cause damage to the drum mechanism (deformation and deflection). HARTANZAH roaster machines of the Danish types have been equipped with the “Safe Unit Shut Down” feature, this feature prevents the drum from stopping when the temperature is still above 40°C. If the drum off button is pressed at a temperature still above 40°C, the system will prevent the drum rotation from stopping until the temperature is below the safe limit and the system will stop the drum rotation automatically.
- Disconnect the power cable connected to the unit and cyclone.
- Clean the dirt on the chaff tray.
- Clean the dirt under the cooling tray.

4 Roaster Maintenance

The information described in this book should be considered as a minimum maintenance recommendation. The maintenance time depends on the operating conditions, or the time suggested by HARTANZAH.

! Machine maintenance must be carried out by experienced operators who fully understand the risks that can occur due to negligence during maintenance.

4.1 Lubrication

The lubricant used must be clean of dirt, dust, and other unwanted material content. Here are the parts that need lubrication.

4.2 Drum Front Bearing

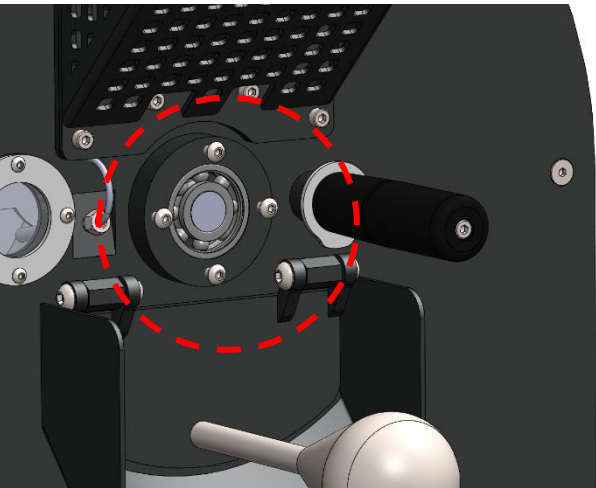

Lubricate the drum front bearing for a minimum of every 500 times the roasting process or if necessary. Use food-grade lubricant to lubricate this part.

Recommended food-grade lubricant specifications:
LGFP 2 food-grade lubricant. Or RIVOLTA F.L.G.GT-2



4.2.1 How to Lubricate the Drum Front Bearing

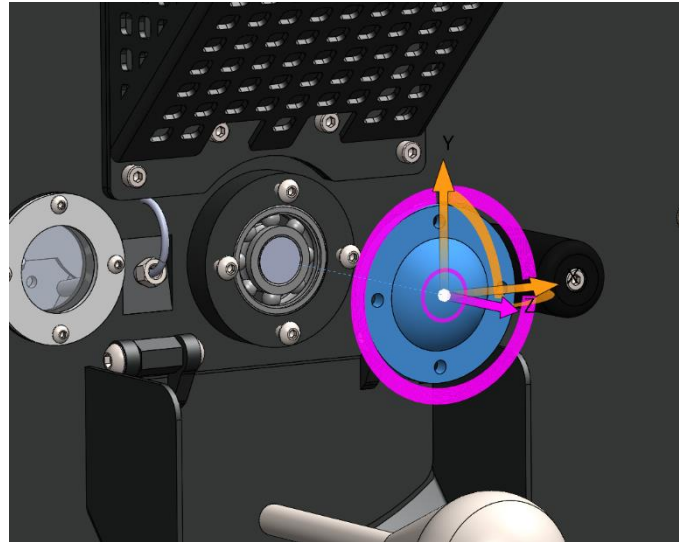
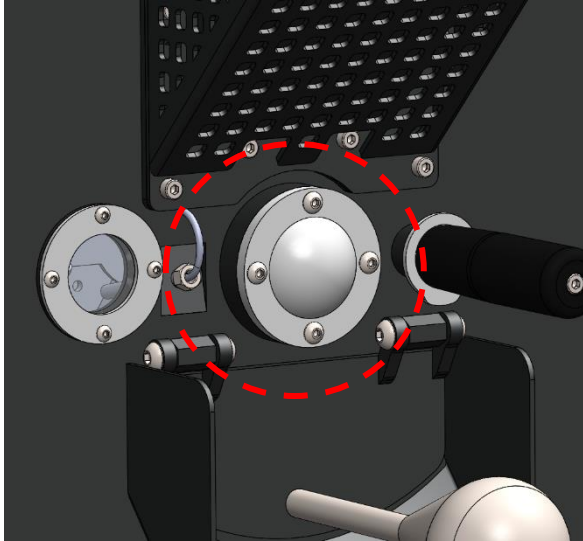

1. Do it when the engine is cold and the drum is not rotating. Unscrew all the bolts on the front (bearing cap).

2. Slowly remove the bearing cap, and place it in a safe place.

Equipment needed: L key and rag.

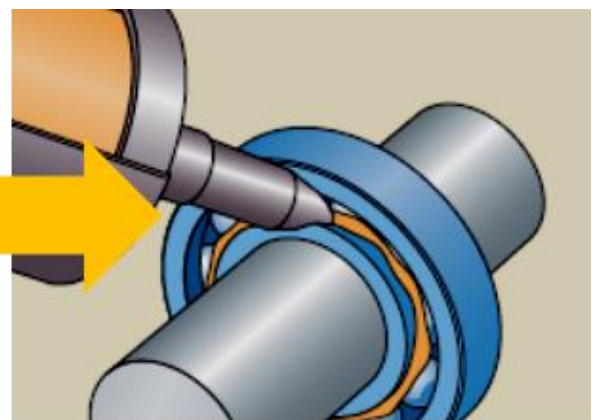
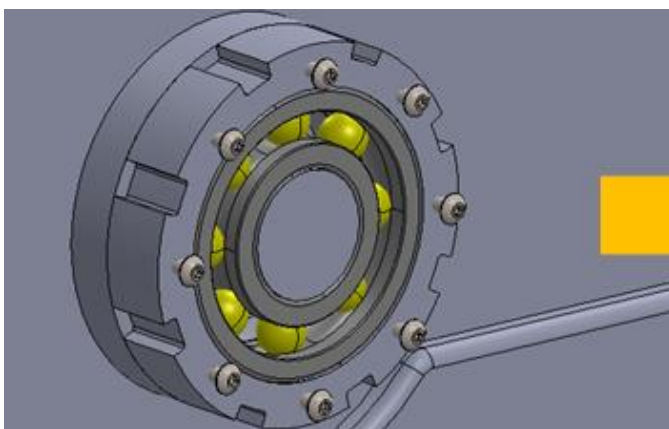

3. Lubricate the bearing parts with food-grade lubricant.

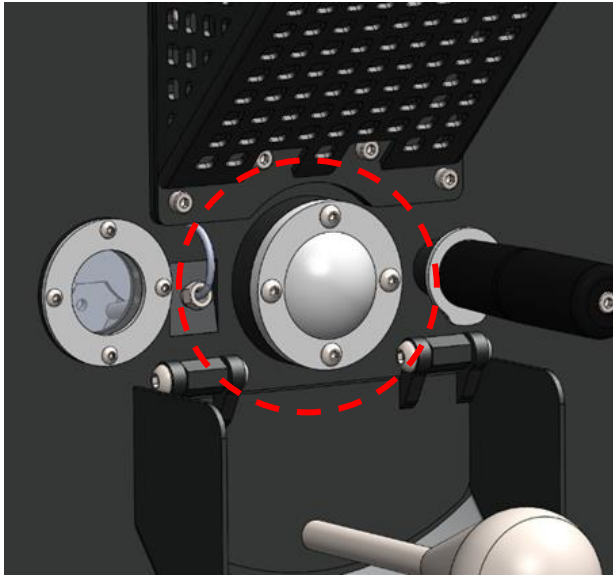

4. Close the bearing cap again and install and re-tighten the bearing cap bolts.

4.3 Bearing Block

Lubricate the bearing block every 5,000 times during the roasting process or at least once a year.

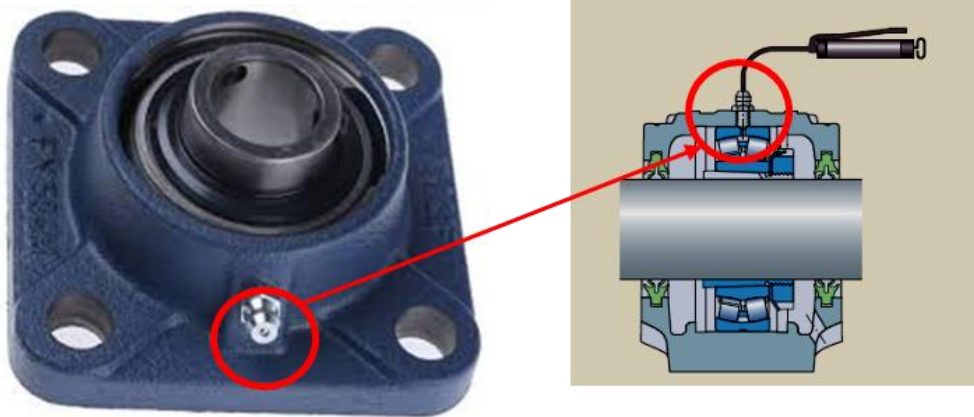

4.3.1 How to Lubricate the Bearing Block

- Perform lubrication when the engine is cold and the shaft is not rotating.
- Clean the lubricant inlet fittings.
- Lubricate the bearings using a grease pump.
- Clean up any spilled lubricant residue.

Equipment needed: grease pump and rags.

4.3.2 Bearing Block Location

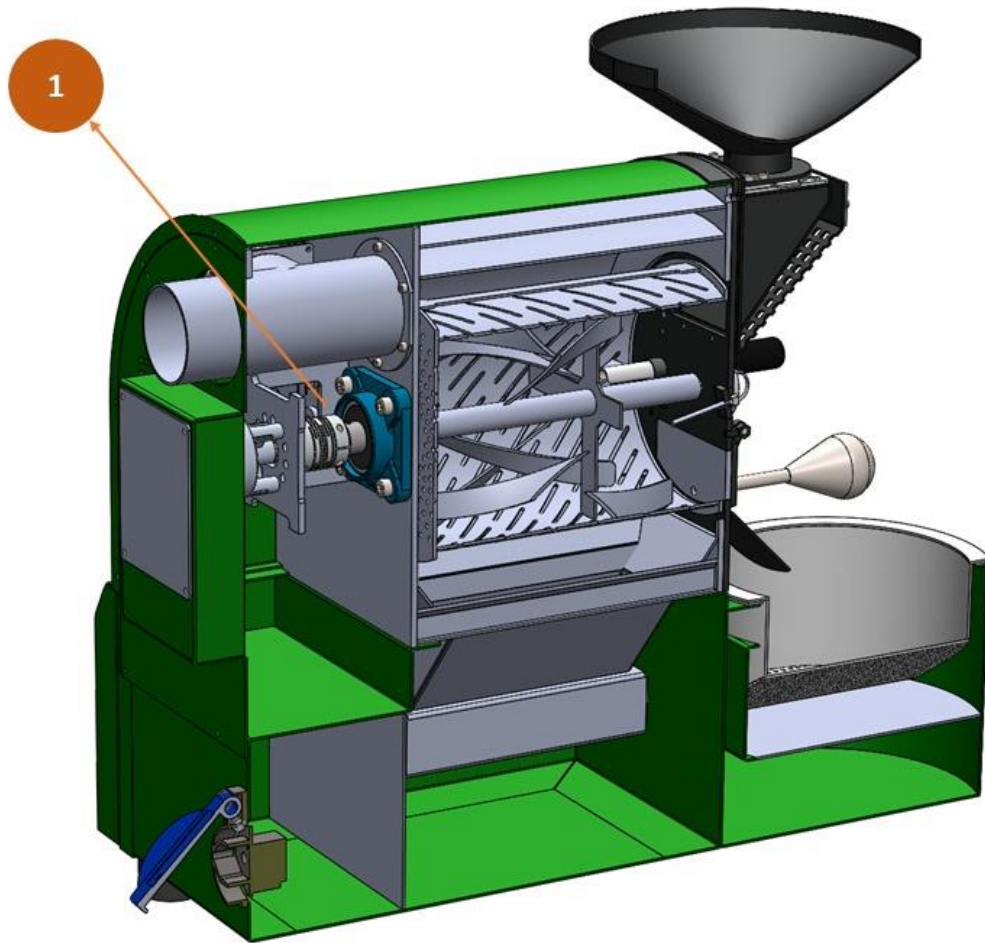

Bearing block located behind the drum at the back of the machine

Lubricate when the engine is cold and the shaft is not rotating.

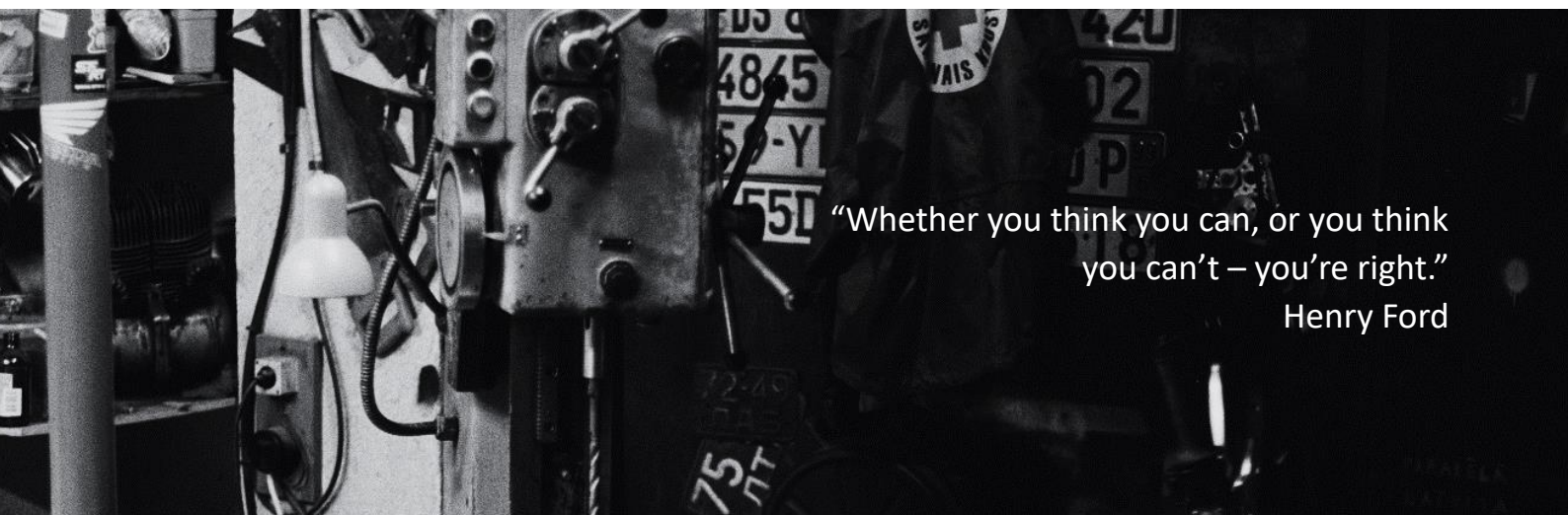

“Whether you think you can, or you think you can’t – you’re right.”
Henry Ford

4.4 Cleaning the Machine

The machine should only be cleaned after it has cooled completely. To clean dust and dirt on the surface of the machine, clean it with a damp cloth and then wipe it dry. Do not use sharp objects or abrasives to clean. Before the cleaning process, be sure to turn off the gas supply, and the electricity supply first.

In the first 30 hours of operation (new machine), don't clean the front of the machine (face flange), especially when it's warm! Heat-resistant paint must burn first and cleaned the paint layer can potentially peel off.

5 Transport, Packing, and Storage

Transport and installation of the machine must be carried out by trained technicians and comply with work safety requirements.

Check all units after delivery, check completeness, and report to the delivery vendor if there is damage caused by an error during delivery.

Use proper lifting equipment. Do not force lift the machine if there is no proper lifting equipment. Transport equipment and lifting equipment should be selected according to the weight of each unit.

If the machine is stored for more than one month, it must be stored in the right way.

- Store the machine in a dry place
- Do not place anything on the machine!
- Protect the machine from dirt, moisture, and dust!
- Machine components that are not coated with paint must be protected from corrosion by lubricating the surface.

6 Machine Installation and Placement

The machine was sent by HARTANZAH using wooden packaging. Unpack the wood carefully with the proper tools. Carelessness can cause damage to the machine.

Use proper lifting equipment to lift the machine. Do not force lift the machine if there is no proper lifting equipment. Transport equipment and lifting equipment should be selected according to the weight of each unit.



WWW.HARTANZAH.COM

Gedung Artha Graha, 26 Floor (SCBD) Unit 2601, Jalan Jend. Sudirman Jakarta
Selatan DKI Jakarta 12190